

FOG ENFORCER XL

Series HDPE Interceptors

Specification: FOG ENFORCER **XL-1000** grease interceptor with 1000 U.S. gallons of liquid holding capacity has a limited lifetime warranty and is made in the U.S.A. out of seamless, rotationally molded High Density Polyethylene with 3/8" uniform wall thickness. Interceptor is designed for above or below ground installation and includes an adjustable lid system, sample port access, internal baffle, deep seal trap covered by lid, internal air relief by-pass, stainless steel calibrated orifice plate (internal flow control), base for support and floor level installation and 4" no hub inlet and outlet connections. Steel encased composite lids provide a water / gas tight seal and have a minimum of 20,000 LB. load capacity - in accordance with the loading requirements of AASHTO H20. The high density polyethylene material is PE 3135 from Dow 9.39 with a density of 0.939 g/cm3. Note that the interceptor is tested and certified to the ASME A112.14.3, CSA B481 and ANSI Z1001 Standards and listed with I.A.P.M.O.

Function: Used in in restaurants, kitchens, institutions, industrial facilities such as food processing and packaging plants and other types of food processing areas where fat, oil and grease (FOG) drains with the waste water.

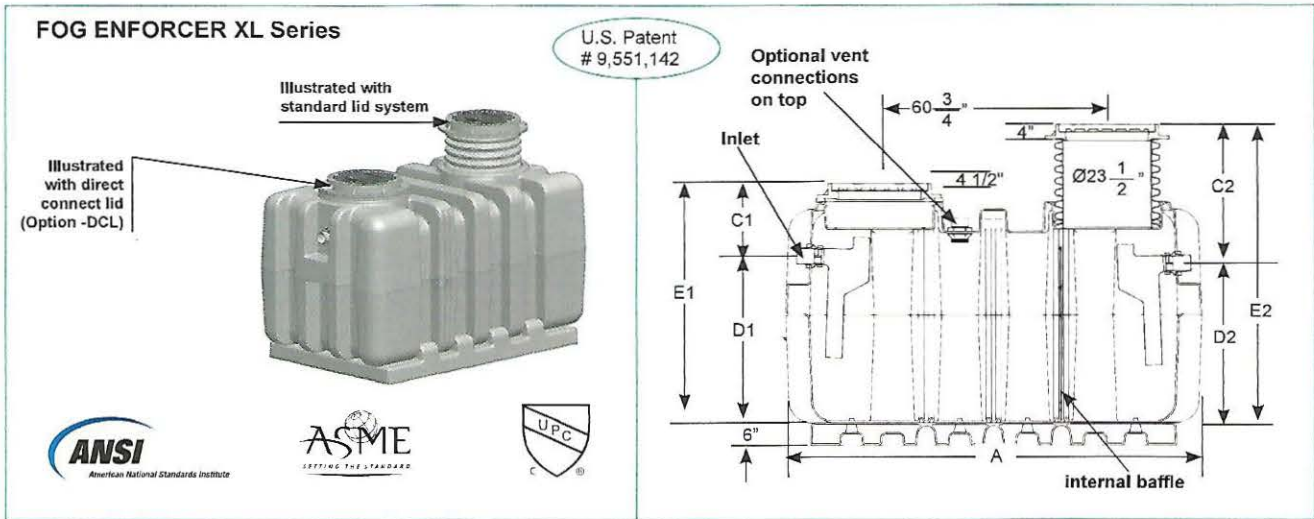

| Model | Liquid Holding Capacity | Flow Rate (GPM) | A | Width B | C' Dim. | C² Dim. | D¹ Dim. | D² Dim. | E¹ Dim. | E² Dim. | F Connection Size | Shipping Weight (Lbs.) |
|------------|-----------------------------------|-----------------|----------------|---------------|-----------------|-----------------|------------------|------------------|---------------|------------------|-------------------|------------------------|
| FE-XL-1000 | 1000 U.S. Gallons 3,790 litres | 250 | 111" 2820mm | 64" 1630mm | 18.75" 476mm | 37.25" 946mm | 45.25" 1149mm | 43.25" 1099mm | 64" 1626mm | 61.50" 1562mm | 4" 102mm | 1,075 |

| Suffix | Description |
|---------------------------------|--|
| <input type="checkbox"/> -AK | High water anchor kit (set of two) |
| <input type="checkbox"/> -C | Lid extension (specify dimension required) |
| <input type="checkbox"/> -COA | Coalescer Pack |
| <input type="checkbox"/> -DI | Ductile iron lid & collar |
| <input type="checkbox"/> -DP | Dosing pump |
| <input type="checkbox"/> -EP | Enzyme port |
| <input type="checkbox"/> -FL-C | Membrane clamp kit |
| <input type="checkbox"/> -F6 | 6" No Hub Inlet / Outlet connection (flow rate of 500 GPM with 6" connections) |
| <input type="checkbox"/> -HLA | High level alarm and float switch (to be installed on site) |
| <input type="checkbox"/> -LHSI | 4" no hub inlet on left hand side |
| <input type="checkbox"/> -LHSO | 4" no hub outlet on left hand side |
| <input type="checkbox"/> -RHSI | 4" no hub inlet on right hand side |
| <input type="checkbox"/> -RHSO | 4" no hub outlet on right hand side |
| <input type="checkbox"/> -RPO | 4" Remote pump outlet connections on top of interceptor - specify location and number required |
| <input type="checkbox"/> -SB | Sediment bucket |
| <input type="checkbox"/> -SP | External Sample Port (for existing construction, Inlet and Outlet on the same level) |
| <input type="checkbox"/> -SP-OF | External Sample Port (for new construction, Inlet higher than the outlet). |
| <input type="checkbox"/> -SST | Fire resistant fabricated stainless steel interceptor |
| <input type="checkbox"/> -ST | Fire resistant fabricated 10 gauge powder epoxy coated steel interceptor |
| <input type="checkbox"/> -V | Vent connection - 4" (specify number required and location - side and / or top) |

CALIFORNIA PROPOSITION 65 WARNING. This product contains chemicals known to the State of California to cause cancer and birth defects or other reproductive harm.

| | |
|--------------------|--------------------------|
| Job Name: _____ | Page No: _____ |
| Section No: _____ | Contractor: _____ |
| Schedule No: _____ | Purchase Order No: _____ |

www.fogenforcer.com • www.solidsenforcer.com • Toll Free (844) 235-0369